



SPORTON LAB.

Certificate No: EC833116

CERTIFICATE

- **EQUIPMENT : Case + DC BOARD**
- MODEL NO. : 5677 + MX-0608A**
- APPLICANT : MOREX INFORMATION ENTERPRISE CO., LTD.**
No. 197, Sec. 1, Chung Hsing Rd.,
Wu-Ku Hsiang, Taipei Hsien, Taiwan, R.O.C.



I HEREBY

CERTIFY THAT:

THE MEASUREMENTS SHOWN IN THIS TEST REPORT WERE MADE IN ACCORDANCE WITH THE PROCEDURES GIVEN IN **EUROPEAN COUNCIL DIRECTIVE 2004/108/EC**. THE EQUIPMENT WAS **PASSED** THE TEST PERFORMED ACCORDING TO **European Standard EN 55022:2006 Class B, EN 61000-3-2:2006, EN 61000-3-3:1995/A1:2001/A2:2005 and EN 55024:1998/A1:2001/A2:2003 (IEC 61000-4-2:1995/A2:2000, IEC 61000-4-3:2002, IEC 61000-4-4:2004, IEC 61000-4-5:1995/A1:2000, IEC 61000-4-6:1996/A1:2000, IEC 61000-4-8:1993/A1:2000, IEC 61000-4-11:1994/A1:2000)**. THE TEST WAS CARRIED OUT ON **Apr. 21, 2008** AT **SPORTON INTERNATIONAL INC. LAB.**

Castries Huang Apr. 21 2008
Castries Huang
Supervisor



CE EMC TEST REPORT

according to

**EUROPEAN STANDARD EN 55022:2006 Class B,
EN 61000-3-2:2006, EN 61000-3-3:1995/A1:2001/A2:2005 and
EN 55024:1998/A1:2001/A2:2003 (IEC 61000-4-2:1995/A2:2000,
IEC 61000-4-3:2002, IEC 61000-4-4:2004,
IEC 61000-4-5:1995/A1:2000, IEC 61000-4-6:1996/A1:2000,
IEC 61000-4-8:1993/A1:2000, IEC 61000-4-11:1994/A1:2000)**

Equipment : Case + DC BOARD

Model No. : 5677 + MX-0608A

Applicant : **MOREX INFORMATION ENTERPRISE CO., LTD.**
No. 197, Sec. 1, Chung Hsing Rd.,
Wu-Ku Hsiang, Taipei Hsien, Taiwan, R.O.C.

- The test result refers exclusively to the test presented test model / sample.
- Without written approval of SPORTON International Inc., the test report shall not be reproduced except in full.
- This test report is only applicable to European Community.

SPORTON International Inc.

6F, No. 106, Sec. 1, Hsin Tai Wu Rd., Hsi Chih, Taipei Hsien, Taiwan, R.O.C.

Table of Contents

History of this test report.....	iii
CERTIFICATE OF COMPLIANCE.....	1
1. General Description of Equipment under Test.....	2
1.1. Applicant.....	2
1.2. Manufacturer.....	2
1.3. Basic Description of Equipment under Test.....	2
1.4. Feature of Equipment under Test.....	2
2. Test Configuration of Equipment under Test.....	3
2.1. Test Manner.....	3
2.2. Description of Test System.....	3
3. Test Software.....	7
4. General Information of Test.....	8
4.1. Test Facility.....	8
4.2. Test Voltage.....	8
4.3. Standard for Methods of Measurement.....	8
4.4. Test in Compliance with.....	8
4.5. Frequency Range Investigated.....	8
4.6. Test Distance.....	8
5. Test of Conducted Powerline.....	9
5.1. Description of Major Test Instruments.....	9
5.2. Test Procedures.....	9
5.3. Typical Test Setup Layout of Conducted Powerline.....	10
5.4. Test Result of AC Powerline Conducted Emission.....	11
5.5. Photographs of Conducted Powerline Test Configuration.....	13
6. Test of Radiated Emission.....	14
6.1. Description of Major Test Instruments.....	14
6.2. Test Procedures.....	15
6.3. Typical Test Setup Layout of Radiated Emission.....	16
6.4. Test Result of Radiated Emission.....	17
6.5. Photographs of Radiated Emission Test Configuration.....	21
7. Harmonics Test.....	22
8. Voltage Fluctuations Test.....	23
8.1. Standard.....	23
8.2. Test Procedure.....	23
8.3. Test Equipment Settings.....	23
8.4. Test Setup.....	23
8.5. Test Result of Voltage Fluctuation and Flicker Test.....	24
8.6. Photographs of Harmonics Test, Voltage Fluctuation and Flicker Test.....	25
9. Electrostatic Discharge Immunity Test (ESD).....	26
9.1. Test Setup.....	26
9.2. Test Setup for Tests Performed in Laboratory.....	27
9.3. ESD Test Procedure.....	28
9.4. Test Severity Levels.....	29
9.5. Test Points.....	30
9.6. Photographs of Electrostatic Discharge Immunity Test.....	31
10. Radio Frequency Electromagnetic Field Immunity Test (RS).....	32

10.1. Test Setup32

10.2. Test Procedure.....33

10.3. Test Severity Levels33

10.4. Photographs of Radio Frequency Electromagnetic Field Immunity Test34

11. Electrical Fast Transient/Burst Immunity Test (EFT/BURST)35

11.1. Test setup.....35

11.2. Test on Power Line36

11.3. Test on Communication Lines.....36

11.4. Test Procedure.....36

11.5. Test Severity Levels37

11.6. Photographs of Electrical Fast Transient/BURST Immunity Test.....38

12. Surge Immunity Test39

12.1. Test Record.....39

12.2. Test Level.....40

12.3. Test Procedure.....40

12.4. Operating Condition41

12.5. Photographs of Surge Immunity Test.....42

13. Conducted Disturbances Induced by Radio-Frequency Field Immunity Test (CS).....43

13.1. Test Level.....43

13.2. Operating Condition43

13.3. Test Procedure.....44

13.4. Photographs of CS tests45

14. Power Frequency Magnetic Field immunity tests46

14.1. Test Record.....46

14.2. Test Setup46

14.3. Photographs of Power Frequency Magnetic Field Immunity Tests47

15. Voltage Dips and Voltage Interruptions Immunity Tests48

15.1. Test Record of Voltage Interruption48

15.2. Test Record of Voltage Dips48

15.3. Testing Requirement and Procedure49

15.4. Test Conditions49

15.5. Operating Condition49

15.6. Photographs of Voltage Dips and Voltage Interruptions Immunity Tests50

16. List of Measuring Equipment Used51

17. Declaration of Conformity and the CE Mark53

Appendix A. Photographs of EUT..... A1 ~ A8



CERTIFICATE OF COMPLIANCE

according to

**EUROPEAN STANDARD EN 55022:2006 Class B,
EN 61000-3-2:2006, EN 61000-3-3:1995/A1:2001/A2:2005 and
EN 55024:1998/A1:2001/A2:2003 (IEC 61000-4-2:1995/A2:2000,
IEC 61000-4-3:2002, IEC 61000-4-4:2004,
IEC 61000-4-5:1995/A1:2000, IEC 61000-4-6:1996/A1:2000,
IEC 61000-4-8:1993/A1:2000, IEC 61000-4-11:1994/A1:2000)**

Equipment : Case + DC BOARD

Model No. : 5677 + MX-0608A

Applicant : **MOREX INFORMATION ENTERPRISE CO., LTD.**
No. 197, Sec. 1, Chung Hsing Rd.,
Wu-Ku Hsiang, Taipei Hsien, Taiwan, R.O.C.

I **HEREBY** CERTIFY THAT:

The measurements shown in this test report were made in accordance with the procedures given in **EUROPEAN COUNCIL DIRECTIVE 2004/108/EC**. The equipment was **passed** the test performed according to **European Standard EN 55022:2006 Class B, EN 61000-3-2:2006, EN 61000-3-3:1995/A1:2001/A2:2005 and EN 55024:1998/A1:2001/A2:2003 (IEC 61000-4-2:1995/A2:2000, IEC 61000-4-3:2002, IEC 61000-4-4:2004, IEC 61000-4-5:1995/A1:2000, IEC 61000-4-6:1996/A1:2000, IEC 61000-4-8:1993/A1:2000, IEC 61000-4-11:1994/A1:2000)**.

The test was carried out on Apr. 21, 2008 at **SPORTON International Inc. LAB.**

Castries Huang
Supervisor

SPORTON International Inc.

6F, No. 106, Sec. 1, Hsin Tai Wu Rd., Hsi Chih, Taipei Hsien, Taiwan, R.O.C.

1. General Description of Equipment under Test

1.1. Applicant

MOREX INFORMATION ENTERPRISE CO., LTD.
No. 197, Sec. 1, Chung Hsing Rd.,
Wu-Ku Hsiang, Taipei Hsien, Taiwan, R.O.C.

1.2. Manufacturer

Same as 1.1

1.3. Basic Description of Equipment under Test

Equipment : Case + DC BOARD
Model No. : 5677 + MX-0608A
Trade Name : MOREX INFORMATION ENTERPRISE CO., LTD.
Power Supply Type : Switching
AC Power Cord : Non-Shielded, 1.8 m, 3 pin
DC Power Cable : Non-Shielded, 1.5 m

1.4. Feature of Equipment under Test

Please refer to user manual.

2. Test Configuration of Equipment under Test

2.1. Test Manner

- a. During testing, the interface cables and equipment positions were varied according to European Standard EN 55022.
- b. The complete test system included DELL Monitor, HP PS/2 Keyboard, HP PS/2 Mouse, HP Printer, ACEEX Modem, WD HDD, NNNIX RAM, Intel Motherboard, Intel CPU and EUT for EMI test.
- c. The complete test system included DELL LCD Monitor, IBM PS/2 Keyboard, IBM PS/2 Mouse, WD HDD, NNNIX RAM, Intel Motherboard, Intel CPU and EUT for EMS test.
- d. Frequency range investigated: conduction 150 kHz to 30 MHz, radiation 30 MHz to 1000MHz.

2.2. Description of Test System

< EMI >

Support Unit 1. -- Monitor (DELL)

FCC ID	: N/A
Model No.	: E770s
Power Supply Type	: Switching
Power Cord	: Non-Shielded
Serial No.	: SP0029
Data Cable	: Shielded, 1.8m
Remark	: This support device was tested to comply with FCC standards and authorized under a declaration of conformity.

Support Unit 2. -- PS/2 Keyboard (HP)

FCC ID	: N/A
Model No.	: KB-0133
Serial No.	: SP0034
Data Cable	: Shielded, 360 degree via metal backshells, 1.9m
Remark	: This support device was tested to comply with FCC standards and authorized under a declaration of conformity.

Support Unit 3. -- Printer (HP)

FCC ID : B94C2642X
Model No. : C2642A
Power Supply Type : Linear
Power Cord : Non-Shielded
Serial No. : SP0046
Data Cable : Shielded, 360 degree via metal backshells, 1.2m

Support Unit 4. -- Modem (ACEEX)

FCC ID : IFAXDM1414
Model No. : DM1414
Power Supply Type : Linear
Power Cord : Non-Shielded
Serial No. : SP0055
Data Cable : Shielded, 360 degree via metal backshells, 1.15m

Support Unit 5. -- HDD (WD)

Model No. : WD400
Serial No. : SP0128

Support Unit 6. -- RAM (NNNIX)

Model No. : 512M
Serial No. : SP0156

Support Unit 7. -- Motherboard (Intel)

Model No. : E2100882
Serial No. : SP0151

Support Unit 8. -- CPU (Intel)

Spec. : 1.33GHz
Serial No. : SP0112

< EMS >

Support Unit 1. -- LCD Monitor (DELL)

FCC ID : N/A
Model No. : E198WFPF
Power Supply Type : Switching
Power Cord : Non-Shielded
Serial No. : SP0024
Data Cable : Shielded, 1.8m
Remark : This support device was tested to comply with FCC standards and authorized under a declaration of conformity.

Support Unit 2. -- PS/2 Keyboard (IBM)

FCC ID : N/A
Model No. : KB-0225
Serial No. : SP0055
Data Cable : Shielded, 1.8m
Remark : This support device was tested to comply with FCC standards and authorized under a declaration of conformity.

Support Unit 3. -- PS/2 Mouse (IBM)

FCC ID : N/A
Model No. : 23-003285
Serial No. : SP0001
Data Cable : Shielded, 1.8m
Remark : This support device was tested to comply with FCC standards and authorized under a declaration of conformity.

Support Unit 4. -- HDD (WD)

Model No. : WD400
Serial No. : SP0128

Support Unit 5. -- RAM (NNNIX)

Model No. : 512M
Serial No. : SP0156

Support Unit 6. -- Motherboard (Intel)

Model No. : E2100882
Serial No. : SP0151

Support Unit 7. -- CPU (Intel)

Spec. : 1.33GHz

Serial No. : SP0112

3. Test Software

< EMI >

An executive program, "EMCTEST.EXE" under WIN XP, which generates a complete line of continuously repeating " H " pattern was used as the test software.

The program was executed as follows :

- a. Turn on the power of all equipment.
- b. The PC reads the test program from the hard disk drive and runs it.
- c. The PC sends " H " messages to the monitor, and the monitor displays " H " patterns on the screen.
- d. The PC sends " H " messages to the printer, then the printer prints them on the paper.
- e. The PC sends " H " messages to the modem.
- f. The PC sends " H " messages to the internal Hard Disk, and the Hard Disk reads and writes the message.
- g. Repeat the steps from c to f.

< EMS >

An executive program, "EMCTEST.EXE" under WIN XP, which generates a complete line of continuously repeating " H " pattern was used as the test software.

The program was executed as follows :

- a. Turn on the power of all equipment.
- b. The PC reads the test program from the hard disk drive and runs it.
- c. The PC sends " H " messages to the monitor, and the monitor displays " H " patterns on the screen.
- d. The PC sends " H " messages to the internal Hard Disk, and the Hard Disk reads and writes the message.
- e. Repeat the steps from c to d.

4. General Information of Test

4.1. Test Facility

<EMI>

Test Site Location : No. 3, Lane 238, Kang Lo Street, Nei Hwu District,
Taipei 11424, Taiwan, R.O.C.
TEL : 886-2-2631-4739
FAX : 886-2-2631-9740

Test Site No : CO01-NH, OS02-NH

<EMS>

Test Site Location : 3F, No.587, Tanmeu St., Neihu District, Taipei, Taiwan, R.O.C.
TEL : 886-2-2794-8886

4.2. Test Voltage

230V / 50Hz

4.3. Standard for Methods of Measurement

EMI Test (conduction and radiation) : European Standard EN 55022 Class B
Harmonics Test : European Standard EN 61000-3-2.
Voltage Fluctuations Test : European Standard EN 61000-3-3.
EMS Test : European Standard EN 55024.
(ESD: IEC 61000-4-2, RS: IEC 61000-4-3, EFT: IEC 61000-4-4, SURGE: IEC 61000-4-5,
CS: IEC 61000-4-6, Power Frequency Magnetic Field: IEC 61000-4-8, DIPS: IEC 61000-4-11)

4.4. Test in Compliance with

EMI Test (conduction and radiation) : European Standard EN 55022 Class B
Harmonics Test : European Standard EN 61000-3-2.
Voltage Fluctuations Test : European Standard EN 61000-3-3.
EMS Test : European Standard EN 55024.
(ESD: IEC 61000-4-2, RS: IEC 61000-4-3, EFT: IEC 61000-4-4, SURGE: IEC 61000-4-5,
CS: IEC 61000-4-6, Power Frequency Magnetic Field: IEC 61000-4-8, DIPS: IEC 61000-4-11)

4.5. Frequency Range Investigated

- Conducted emission test: from 150 kHz to 30 MHz
- Radiated emission test: from 30 MHz to 1,000 MHz
- Radio frequency electromagnetic field immunity test: 80-1000 MHz

4.6. Test Distance

- The test distance of radiated emission test from antenna to EUT is 10 M
- The test distance of radio frequency electromagnetic field immunity test from antenna to EUT is 3 M

5. Test of Conducted Powerline

Conducted Emissions were measured from 150 kHz to 30 MHz with a bandwidth of 9 kHz and return leads of the EUT according to the methods defined in European Standard EN 55022 Clause 9. The EUT was placed on a nonmetallic stand in a shielded room 0.8 meters above the ground plane as shown in section 5.3. The interface cables and equipment positioning were varied within limits of reasonable applications to determine the position producing maximum conducted emissions.

5.1. Description of Major Test Instruments

● Test Receiver	(R&S ESCS 30)
Attenuation	10 dB
Start Frequency	0.15 MHz
Stop Frequency	30 MHz
IF Bandwidth	9 kHz

5.2. Test Procedures

- a. The EUT was placed on a desk 0.8 meters height from the metal ground plane and 0.4 meter from the conducting wall of the shielding room and it was kept at least 0.8 meters from any other grounded conducting surface.
- b. Connect EUT to the power mains through a line impedance stabilization network (LISN).
- c. All the support units are connect to the other LISN.
- d. The LISN provides 50 ohm coupling impedance for the measuring instrument.
- e. The CISPR states that a 50 ohm, 50 microhenry LISN should be used.
- f. Both sides of AC line were checked for maximum conducted interference.
- g. The frequency range from 150 kHz to 30 MHz was searched.
- h. Set the test-receiver system to Peak Detect Function and Specified Bandwidth with Maximum Hold Mode.

5.3. Typical Test Setup Layout of Conducted Powerline

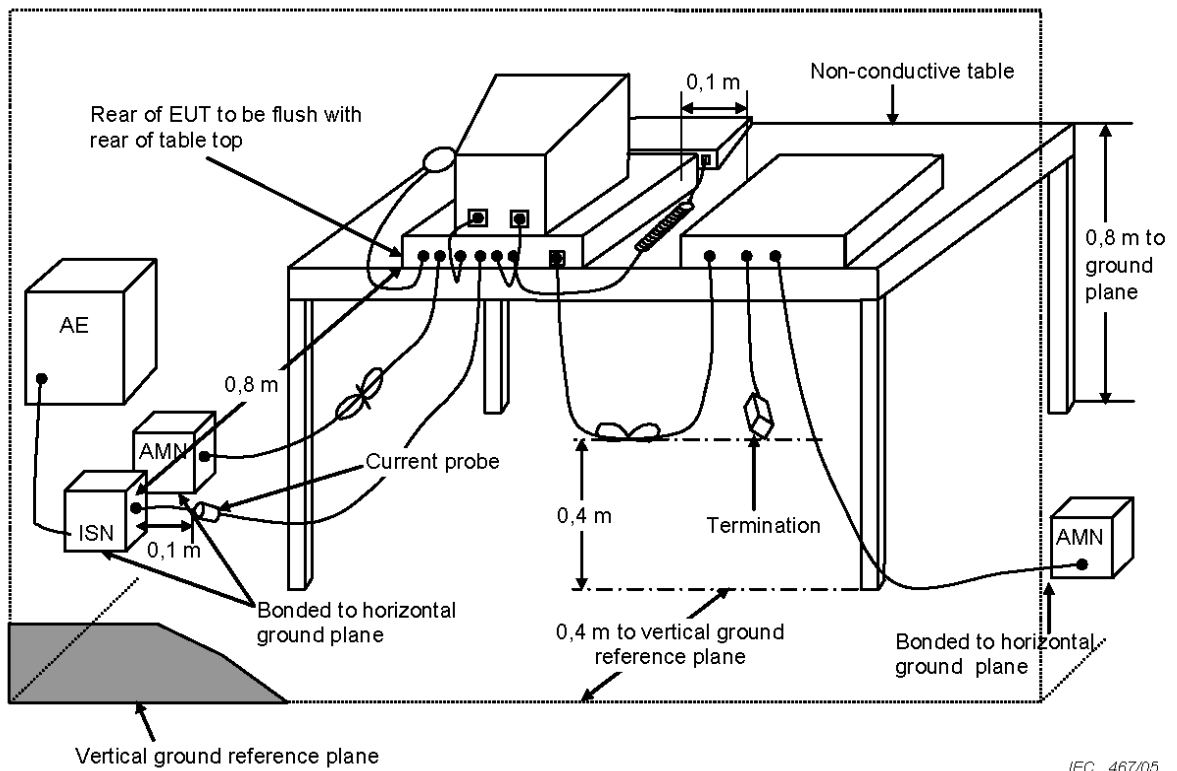

5.4. Test Result of AC Powerline Conducted Emission

- Frequency Range of Test: from 0.15 MHz to 30 MHz
- Temperature: 21
- Relative Humidity: 51 %
- Corrected Reading (dBuV) = LISN Factor + Cable Loss + Read Level = Level
- All emissions not reported here are more than 10 dB below the prescribed limit.

The test was passed at the minimum margin that marked by the frame in the following table.

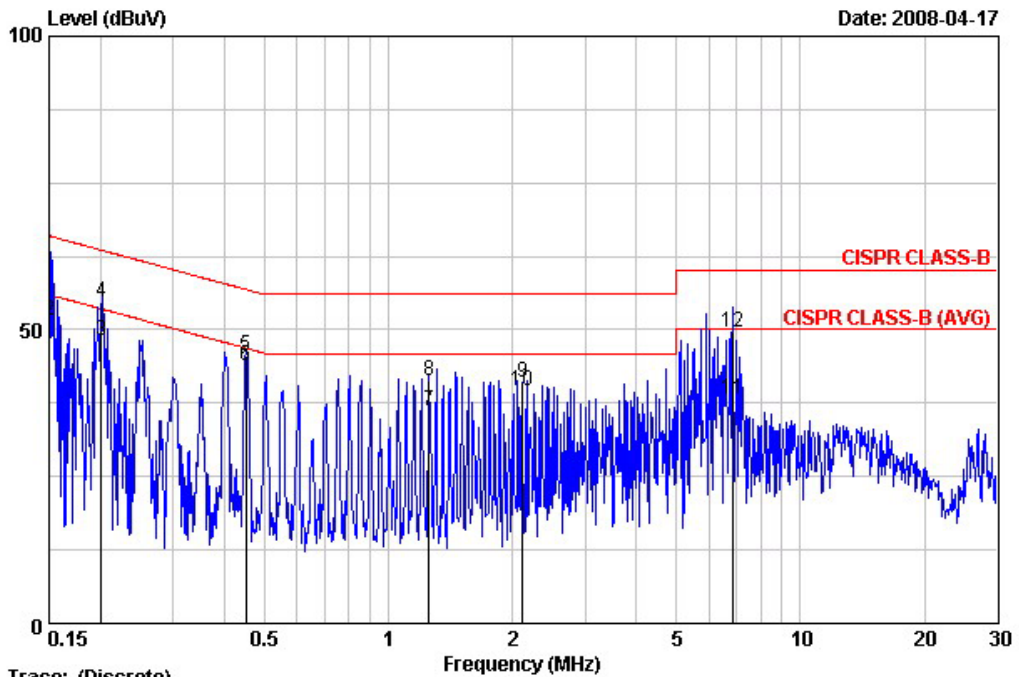

Trace: (Discrete)
 Site : CO01-NH
 Condition : CISPR CLASS-B NNB216Z-99081-961221 LINE
 Input : Case
 power : AC 230V
 memo :
 memo :
 memo :

	Freq	Level	Over Limit	Limit Line	Read Level	LISN Factor	Cable Loss	Remark
	MHz	dBuV	dB	dBuV	dBuV	dB	dB	
1	0.150	62.32	-3.68	66.00	61.83	0.49	0.00	QP
2	0.150	51.51	-4.49	56.00	51.02	0.49	0.00	AVERAGE
3	0.201	48.02	-5.57	53.59	47.51	0.51	0.00	AVERAGE
4	0.201	54.82	-8.77	63.59	54.31	0.51	0.00	QP
5	0.452	45.67	-11.18	56.85	45.17	0.50	0.00	QP
6	0.452	43.87	-2.98	46.85	43.37	0.50	0.00	AVERAGE
7	1.257	36.05	-9.95	46.00	35.59	0.42	0.03	AVERAGE
8	1.257	41.27	-14.73	56.00	40.81	0.42	0.03	QP
9	2.114	41.14	-14.86	56.00	40.66	0.38	0.10	QP
10	2.114	39.62	-6.38	46.00	39.14	0.38	0.10	AVERAGE
11	6.845	38.11	-11.89	50.00	37.65	0.30	0.16	AVERAGE
12	6.845	49.67	-10.33	60.00	49.21	0.30	0.16	QP

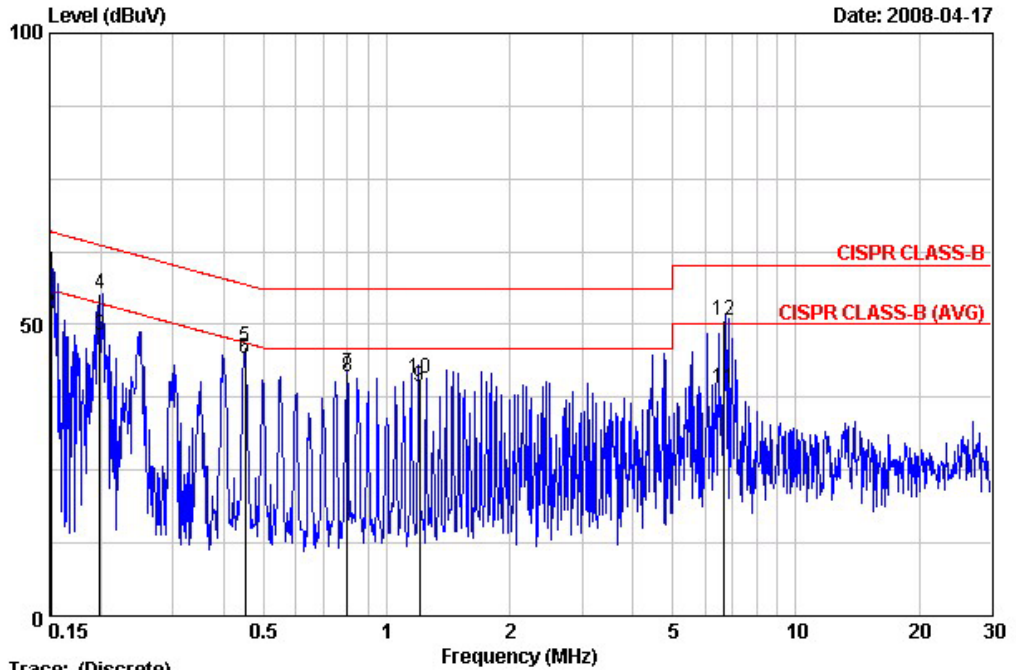

Trace: (Discrete)

Site : CO01-NH
 Condition : CISPR CLASS-B NNB216Z-99081-961221 NEUTRAL
 Input : Case
 power : AC 230V
 memo :
 memo :
 memo :
 memo :

	Freq	Level	Over	Limit	Read	LISN	Cable	Remark
	MHz	dBuV	Limit	Line	Level	Factor	Loss	
			dB	dBuV	dBuV	dB	dB	
1 @	0.151	62.77	-3.18	65.95	62.51	0.26	0.00	QP
2 @	0.151	51.76	-4.19	55.95	51.50	0.26	0.00	AVERAGE
3 @	0.199	48.16	-5.48	53.64	47.89	0.27	0.00	AVERAGE
4	0.199	55.18	-8.46	63.64	54.91	0.27	0.00	QP
5	0.450	46.12	-10.75	56.87	45.83	0.29	0.00	QP
6 @	0.450	44.26	-2.61	46.87	43.97	0.29	0.00	AVERAGE
7	0.800	41.53	-14.47	56.00	41.25	0.28	0.00	QP
8 @	0.800	41.05	-4.95	46.00	40.77	0.28	0.00	AVERAGE
9	1.202	39.29	-6.71	46.00	38.98	0.28	0.03	AVERAGE
10	1.202	40.84	-15.16	56.00	40.53	0.28	0.03	QP
11	6.657	38.92	-11.08	50.00	38.46	0.31	0.16	AVERAGE
12	6.657	50.85	-9.15	60.00	50.39	0.31	0.16	QP

Test Engineer : Eddie
 Eddie Lee

5.5. Photographs of Conducted Powerline Test Configuration

- The photographs show the configuration that generates the maximum emission.

FRONT VIEW



REAR VIEW

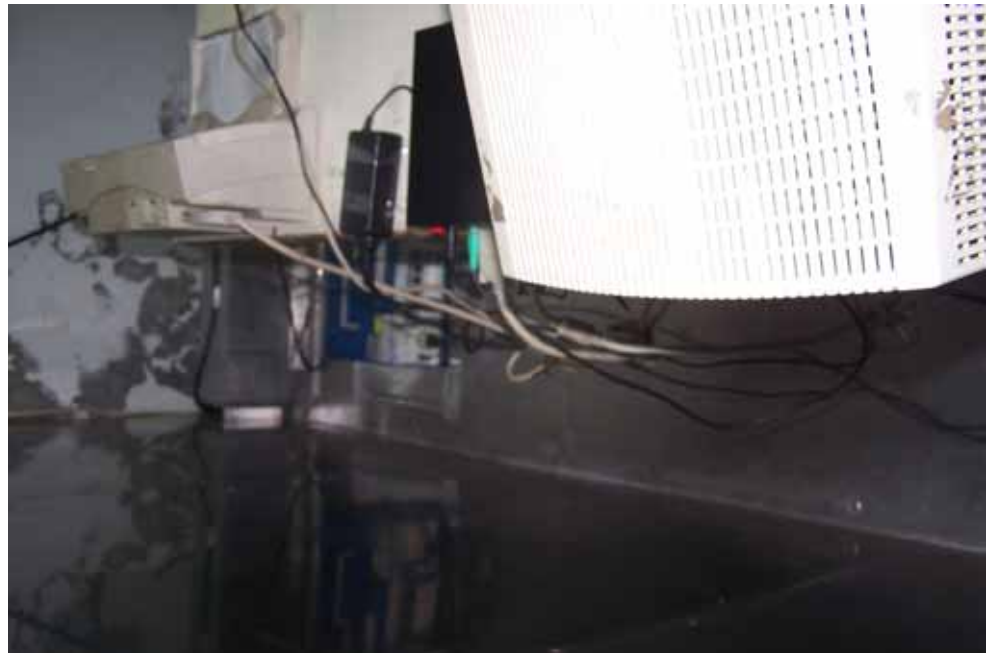

6. Test of Radiated Emission

Radiated emissions from 30 MHz to 1000 MHz were measured with a bandwidth of 120 kHz according to the methods defines in European Standard EN 55022, Clause 10. The EUT was placed on a nonmetallic stand, 0.8 meter above the ground plane, as shown in section 6.3. The interface cables and equipment positions were varied within limits of reasonable applications to determine the positions producing maximum radiated emissions.

6.1. Description of Major Test Instruments

- Amplifier (HP 8447D)
 - RF Gain 25 dB
 - Signal Input 0.1 MHz - 1.3 GHz

- Test Receiver (R&S ESCI)
 - Resolution Bandwidth 120 kHz
 - Frequency Band 9 kHz - 3 GHz
 - Quasi-Peak Detector ON for Quasi-Peak Mode
OFF for Peak Mode

6.2. Test Procedures

- a. The EUT was placed on a rotatable table top 0.8 meter above ground.
- b. The EUT was set 10 meters from the interference receiving antenna which was mounted on the top of a variable height antenna tower.
- c. The table was rotated 360 degrees to determine the position of the highest radiation.
- d. The antenna is a linear dipole and its height is varied between one meter and four meters above ground to find the maximum value of the field strength both horizontal polarization and vertical polarization of the antenna are set to make the measurement.
- e. For each suspected emission the EUT was arranged to its worst case and then tune the antenna tower (from 1 M to 4 M) and turn table (from 0 degree to 360 degrees) to find the maximum reading.
- f. Set the test-receiver system to Peak Detect Function and specified bandwidth with Maximum Hold Mode.
- g. If the emission level of the EUT in peak mode was 3 dB lower than the limit specified, then testing will be stopped and peak values of EUT will be reported, otherwise, the emissions which do not have 3 dB margin will be repeated one by one using the quasi-peak method and reported.

6.3. Typical Test Setup Layout of Radiated Emission

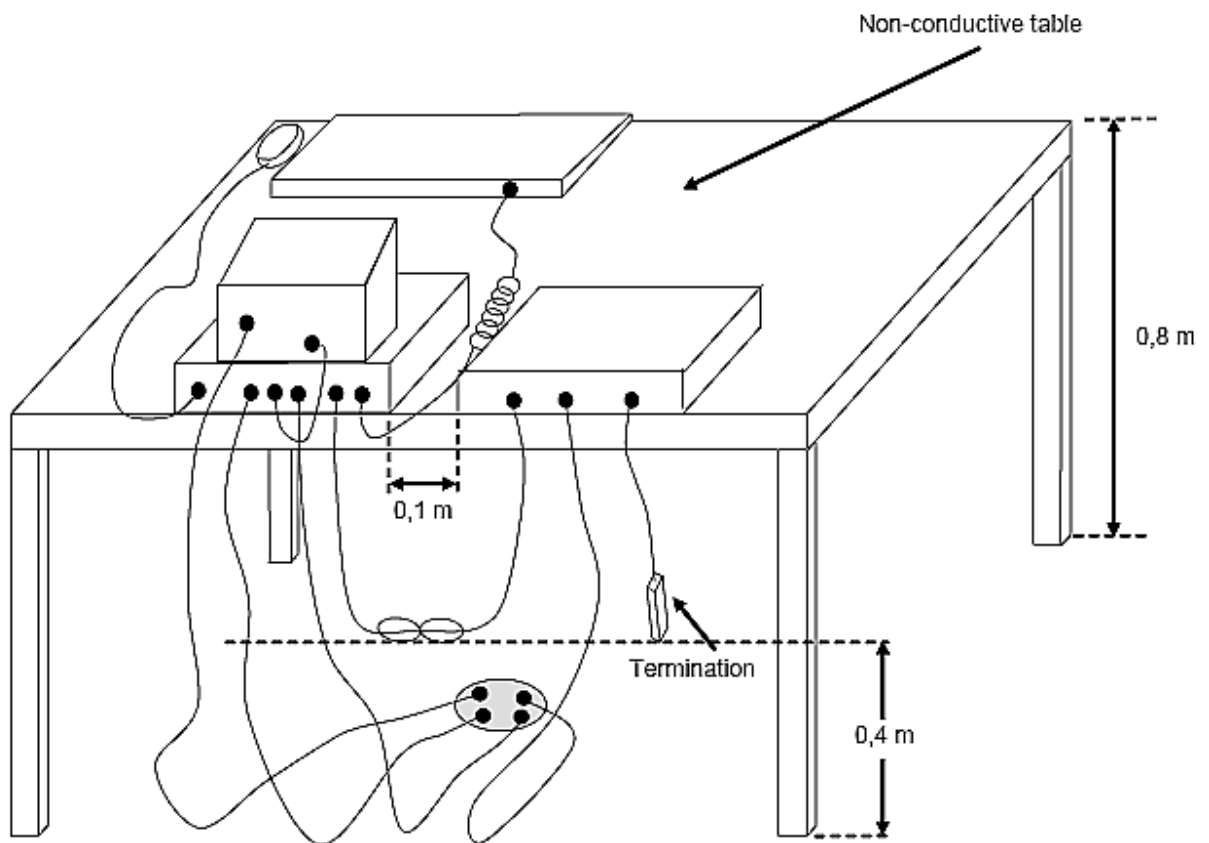

6.4. Test Result of Radiated Emission

- Frequency Range of Test : from 30 MHz to 1000 MHz
- Temperature: 20
- Relative Humidity: 50 %
- Emission level (dBuV/m) = 20 log Emission level (uV/m)
- Corrected Reading: Antenna Factor + Cable Loss + Read Level - Preamp Factor = Level

The test was passed at the minimum margin that marked by the frame in the following test record

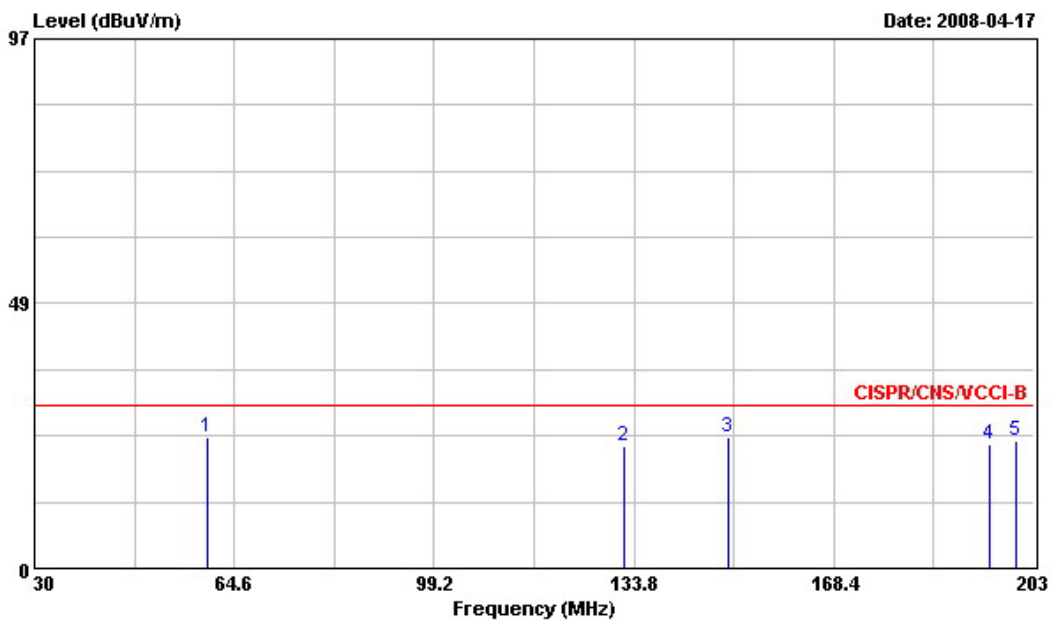

Site : OS02-NH
 Condition : CISPR/CNS/VCCI-B 10m OS02-ANT-12-20-2007 VERTICAL
 EUT : CASE
 POWER : 230VAC
 MEMO :

	Freq	Level	Over Limit	Limit Line	Read Level	Antenna Factor	Cable Loss	Preamp Factor	Remark	Ant Pos	Table Pos
	MHz	dBuV/m	dB	dBuV/m	dBuV	dB/m	dB	dB		cm	deg
1	60.100	24.04	-5.96	30.00	43.59	6.47	1.06	27.08	Peak	---	---
2	132.070	22.39	-7.61	30.00	36.18	11.53	1.52	26.84	Peak	---	---
3	150.060	23.88	-6.12	30.00	38.80	10.20	1.63	26.75	Peak	---	---
4	195.390	22.75	-7.25	30.00	38.23	9.18	1.86	26.52	Peak	---	---
5	200.060	23.43	-6.57	30.00	38.85	9.20	1.88	26.50	Peak	---	---

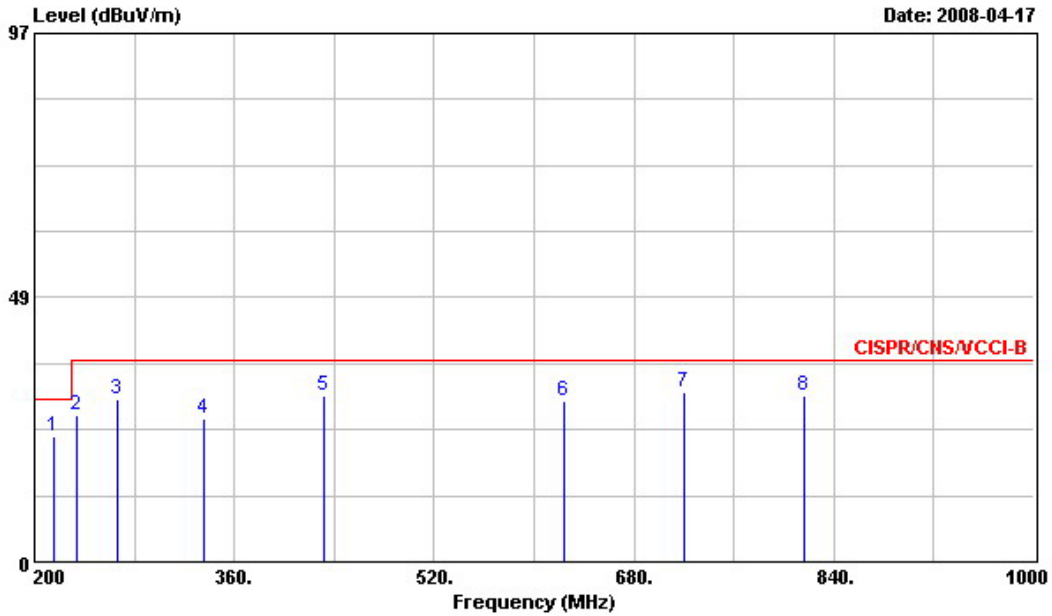

Site : OS02-NH
 Condition : CISPR/CNS/VCCI-B 10m OS02-ANT-12-20-2007 VERTICAL
 EUT : CASE
 POWER : 230VAC
 MEMO :

Freq	Level	Over Limit	Limit Line	ReadAntenna Level	Antenna Factor	Cable Loss	Preamp Factor	Remark	Ant Pos	Table Pos
MHz	dBuV/m	dB	dBuV/m	dBuV	dB/m	dB	dB		cm	deg
1	215.200	23.15	-6.85	30.00	37.56	10.13	1.94	26.48 Peak	---	---
2	233.600	27.05	-9.95	37.00	40.26	11.23	2.03	26.47 Peak	---	---
3	266.400	29.98	-7.02	37.00	41.66	12.58	2.17	26.43 Peak	---	---
4	336.000	26.38	-10.62	37.00	36.57	14.08	2.45	26.72 Peak	---	---
5	432.000	30.43	-6.57	37.00	38.87	16.12	2.84	27.40 Peak	---	---
6	624.000	29.45	-7.55	37.00	34.98	18.75	3.52	27.80 Peak	---	---
7	720.000	31.13	-5.87	37.00	35.74	19.35	3.86	27.82 Peak	---	---
8	816.000	30.63	-6.37	37.00	34.15	20.24	4.11	27.87 Peak	---	---

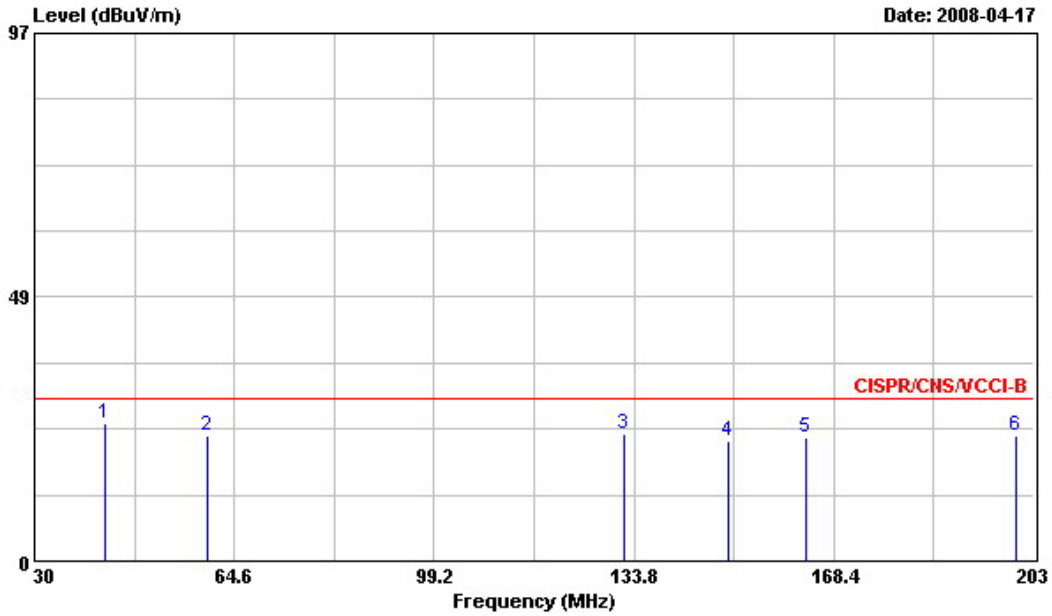

Site : OS02-NH
 Condition : CISPR/CNS/VCCI-B 10m OS02-ANT-12-20-2007 HORIZONTAL
 EUT : CASE
 POWER : 230VAC
 MEMO :

	Freq	Level	Over Limit	Limit Line	ReadAntenna Level	Antenna Factor	Cable Loss	Preamp Factor	Remark	Ant Pos	Table Pos
	MHz	dBuV/m	dB	dBuV/m	dBuV	dB/m	dB	dB		cm	deg
1	42.280	25.20	-4.80	30.00	38.74	12.69	0.91	27.14	Peak	---	---
2	60.100	23.17	-6.83	30.00	42.72	6.47	1.06	27.08	Peak	---	---
3	132.070	23.41	-6.59	30.00	37.20	11.53	1.52	26.84	Peak	---	---
4	150.060	21.97	-8.03	30.00	36.89	10.20	1.63	26.75	Peak	---	---
5	163.560	22.68	-7.32	30.00	38.00	9.67	1.69	26.68	Peak	---	---
6	200.060	23.07	-6.93	30.00	38.49	9.20	1.88	26.50	Peak	---	---

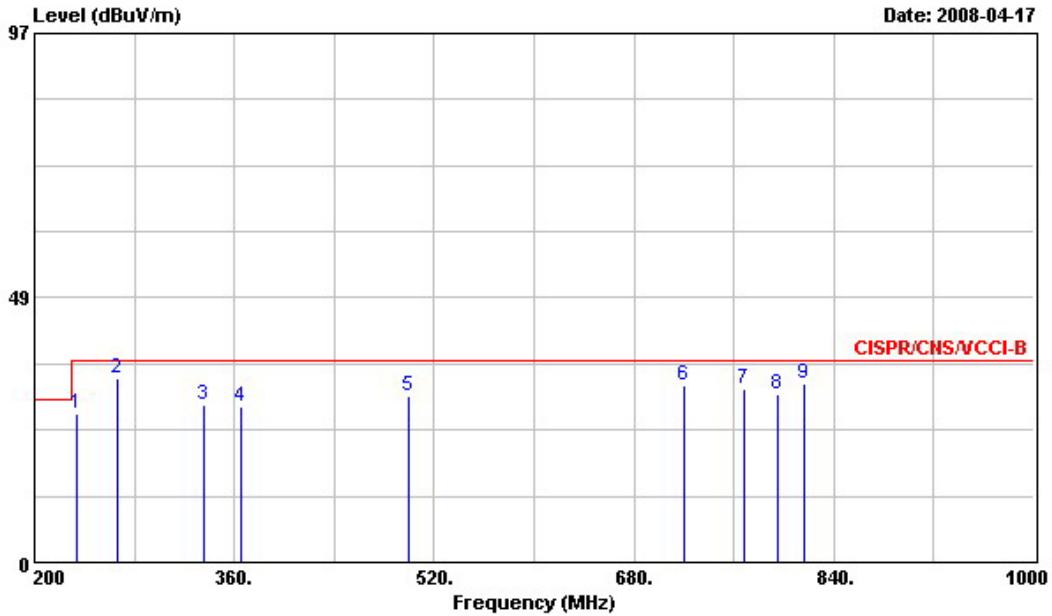

Site : OS02-NH
 Condition : CISPR/CNS/VCCI-B 10m OS02-ANT-12-20-2007 HORIZONTAL
 EUT : CASE
 POWER : 230VAC
 MEMO :

	Freq	Level	Over Limit	Limit Line	ReadAntenna Level	Antenna Factor	Cable Loss	Preamp Factor	Remark	Ant Pos	Table Pos
	MHz	dBuV/m	dB	dBuV/m	dBuV	dB/m	dB	dB		cm	deg
1	233.600	27.24	-9.76	37.00	40.45	11.23	2.03	26.47	Peak	---	---
2	266.400	33.71	-3.29	37.00	45.39	12.58	2.17	26.43	Peak	200	180
3	336.000	28.73	-8.27	37.00	38.92	14.08	2.45	26.72	Peak	---	---
4	365.600	28.61	-8.39	37.00	38.30	14.73	2.57	26.99	Peak	---	---
5	500.000	30.50	-6.50	37.00	37.47	17.53	3.10	27.60	Peak	---	---
6	720.000	32.53	-4.47	37.00	37.14	19.35	3.86	27.82	Peak	---	---
7	768.000	31.86	-5.14	37.00	35.97	19.81	3.95	27.87	Peak	---	---
8	794.400	30.68	-6.32	37.00	34.46	20.06	4.05	27.89	Peak	---	---
9	816.000	32.90	-4.10	37.00	36.42	20.24	4.11	27.87	Peak	---	---

Test Engineer: Chas
 Chas Yeh

6.5. Photographs of Radiated Emission Test Configuration

- The photographs show the configuration that generates the maximum emission.

FRONT VIEW



REAR VIEW



7. Harmonics Test

As specified on clause 7 and figure Z1 of EN 61000-3-2:2006, the limits are not specified for equipment with a rated power of 75W or less.

The EUT meets the above condition, so it conforms to EN 61000-3-2.

8. Voltage Fluctuations Test

8.1. Standard

- Product Standard : EN 61000-3-3:1995/A1:2001/A2:2005

8.2. Test Procedure

The equipment shall be tested under the conditions of **Clause 5**.

The total impedance of the test circuit, excluding the appliance under test, but including the internal impedance of the supply source, shall be equal to the reference impedance. The stability and tolerance of the reference impedance shall be adequate to ensure that the overall accuracy of $\pm 8\%$ is achieved during the whole assessment procedure.

8.3. Test Equipment Settings

- Line Voltage: 230 V
- Line Frequency: 50 Hz
- Measurement Delay: 10.0 seconds
- Pst Integration Time: 10 minutes
- Pst Integration Periods: 1
- Test Duration: 00:10:00 minutes

8.4. Test Setup

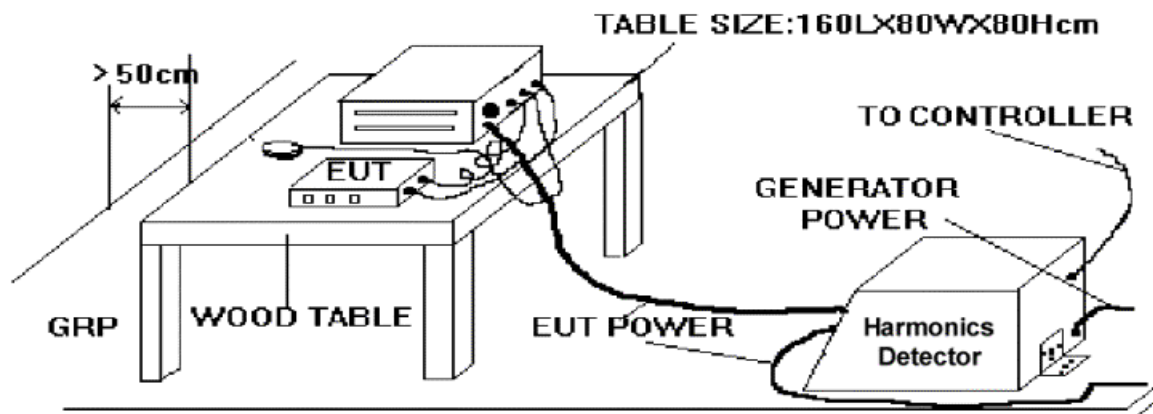

8.5. Test Result of Voltage Fluctuation and Flicker Test

8.5.1. Test Data of Voltage Fluctuation and Flicker

- FINAL TEST RESULT : **PASS**
- Temperature : 21 °C
- Relative Humidity : 40 %
- Test Date : Apr. 18, 2008

Urms = 230.1V Freq = 50.000 Range: 5 A
Irms = 0.352A Ipk = 2.151A cf = 6.118
P = 27.98W S = 80.90VA pf = 0.346

Test - Time : 1 x 10min = 10min (100 %)

LIN (Line Impedance Network) : SLIN 0.24ohm +j0.15ohm N:0.16ohm +j0.10ohm

Limits : Plt : 0.65 Pst : 1.00
 dmax : 4.00 % dc : 3.30 %
 dtLim: 3.30 % dt>Lim: 500ms

Test completed, Result: PASSED

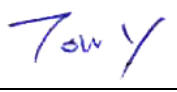
Test Engineer: 
 Tony Hsu

8.6. Photographs of Harmonics Test, Voltage Fluctuation and Flicker Test

FRONT VIEW



REAR VIEW



9. Electrostatic Discharge Immunity Test (ESD)

- FINAL TEST RESULT : **PASS**
- Pass Performance Criteria : A
- Required Performance Criteria : B
- Basic Standard : IEC 61000-4-2:1995/A2:2000
- Product Standard : EN 55024:1998/A1:2001/A2:2003
- Level : 3 for air discharge,
: 2 for contact discharge
- Tested Voltage : $\pm 2 / \pm 4 / \pm 8$ kV for air discharge,
: $\pm 2 / \pm 4$ kV for contact discharge
- Temperature : 21
- Relative Humidity : 39 %
- Atmospheric Pressure : 103 kPa
- Test Date : Apr. 21, 2008
- Observation : Normal.

9.1. Test Setup

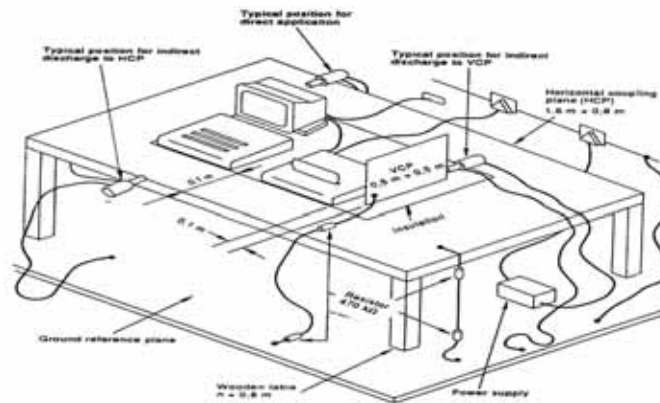

The test setup consists of the test generator, EUT and auxiliary instrumentation necessary to perform DIRECT and INDIRECT application of discharges to the EUT as applicable, in the following manner :

- a. CONTACT DISCHARGE to the conductive surfaces and to coupling plane;
- b. AIR DISCHARGE at insulating surfaces.

The preferred test method is that of type tests performed in laboratories and the only accepted method of demonstrating conformance with this standard. The EUT was arranged as closely as possible to arrangement in final installed conditions.

9.2. Test Setup for Tests Performed in Laboratory

A ground reference plane was provided on the floor of the test site. It was a metallic sheet (copper or aluminum) of 0.25 mm, minimum thickness; other metallic may be used but they shall have at least 0.65 mm thickness. In the SPORTON EMC LAB., we provided 1 mm thickness aluminum ground reference plane or 1 mm thickness stainless steel ground reference plane. The minimum size of the ground reference plane is 1 m x 1 m, the exact size depending on the dimensions of the EUT. It was connected to the protective grounding system.

The EUT was arranged and connected according to its functional requirements. A distance of 1m minimum was provided between the EUT and the wall of the lab. and any other metallic structure. In cases where this length exceeds the length necessary to apply the discharges to the selected points, the excess length shall, where possible, be placed non-inductively off the ground reference plane and shall not come closer than 0.2m to other conductive parts in the test setup.

Where the EUT is installed on a metal table, the table was connected to the reference plane via a cable with a 470k ohm resistor located at each end, to prevent a build-up of charge. The test setup was consist a wooden table, 0.8m high, standing on the ground reference plane. A HCP, 1.6 m x 0.8 m, was placed on the table. The EUT and cables was isolated from the HCP by an insulating support 0.5 mm thick. The VCP size, 0.5 m x 0.5 m.

9.3. ESD Test Procedure

- a. In the case of air discharge testing the climatic conditions shall be within the following ranges:
 - ambient temperature: 15°C to 35°C;
 - relative humidity : 30% to 60%;
 - atmospheric pressure : 86 kPa (860 mbar) to 106 kPa (1060 mbar).
- b. Test programs and software shall be chosen so as to exercise all normal modes of operation of the EUT. The use of special exercising software is encouraged, but permitted only where it can be shown that the EUT is being comprehensively exercised.
- c. The test voltage shall be increased from the minimum to the selected test severity level, in order to determine any threshold of failure. The final severity level should not exceed the product specification value in order to avoid damage to the equipment.
- d. The test shall be performed with both air discharge and contact discharge. On preselected points at least 10 single discharges (in the most sensitive polarity) shall be applied on air discharge. On preselected points at least 25 single discharges (in the most sensitive polarity) shall be applied on contact discharge.
- e. For the time interval between successive single discharges an initial value of one second is recommended. Longer intervals may be necessary to determine whether a system failure has occurred.
- f. In the case of contact discharges, the tip of the discharge electrode shall touch the EUT before the discharge switch is operated.
- g. In the case of painted surface covering a conducting substrate, the following procedure shall be adopted:
 - If the coating is not declared to be an insulating coating by the equipment manufacturer, then the pointed tip of the generator shall penetrate the coating so as to make contact with the conducting substrate.
 - Coating declared as insulating by the manufacturer shall only be submitted to the air discharge.
 - The contact discharge test shall not be applied to such surfaces.
- h. In the case of air discharges, the round discharge tip of the discharge electrode shall be approached as fast as possible (without causing mechanical damage) to touch the EUT . After each discharge, the ESD generator (discharge electrode) shall be removed from the EUT. The generator is then retriggered for a new single discharge. This procedure shall be repeated until the discharges are completed. In the case of an air discharge test, the discharge switch, which is used for contact discharge, shall be closed.

9.4. Test Severity Levels

9.4.1. Contact Discharge

Level	Test Voltage (kV) of Contact discharge
1	±2
2	±4
3	±6
4	±8
X	Specified

Remark : "X" is an open level.

9.4.2. Air Discharge

Level	Test Voltage (kV) of Air Discharge
1	±2
2	±4
3	±8
4	±15
X	Specified

Remark : "X" is an open level.

9.5. Test Points

9.5.1. Test Result of Air Discharge

Test Point	Voltage	Tested No.
Power Switch	$\pm 2 / \pm 4 / \pm 8$ kV	BY 10

9.5.2. Test Result of Contact Discharge

Test Point	Voltage	Tested No.
HCP (At Front)	$\pm 2 / \pm 4$ kV	BY 25
HCP (At Left)	$\pm 2 / \pm 4$ kV	BY 25
HCP (At Right)	$\pm 2 / \pm 4$ kV	BY 25
HCP (At Rear)	$\pm 2 / \pm 4$ kV	BY 25
VCP (At Front)	$\pm 2 / \pm 4$ kV	BY 25
VCP (At Left)	$\pm 2 / \pm 4$ kV	BY 25
VCP (At Right)	$\pm 2 / \pm 4$ kV	BY 25
VCP (At Rear)	$\pm 2 / \pm 4$ kV	BY 25
CASE	$\pm 2 / \pm 4$ kV	BY 25
SCREW	$\pm 2 / \pm 4$ kV	BY 25
PS/2 PORT	$\pm 2 / \pm 4$ kV	BY 25

Test Engineer: Tony Hsu
 Tony Hsu

9.6. Photographs of Electrostatic Discharge Immunity Test

FRONT VIEW



REAR VIEW



10. Radio Frequency Electromagnetic Field Immunity Test (RS)

- FINAL TEST RESULT : **PASS**
- Pass Performance Criteria : A
- Required Performance Criteria : A
- Basic Standard : IEC 61000-4-3:2002
- Product Standard : EN 55024:1998/A1:2001/A2:2003
- Level : 2
- Frequency Range : 80-1000 MHz
- Frequency : 80, 120, 160, 230, 434, 400, 600, 863, 900MHz
- Dwell Time : 3 seconds, 3 Min for additional selection frequency
- Field Strength : 3 V/m (Modulated 80% AM at 1KHz)
- Temperature : 21
- Relative Humidity : 40 %
- Atmospheric Pressure : 103 kPa
- Test Date : Apr. 21, 2008
- Observation : Normal

10.1. Test Setup

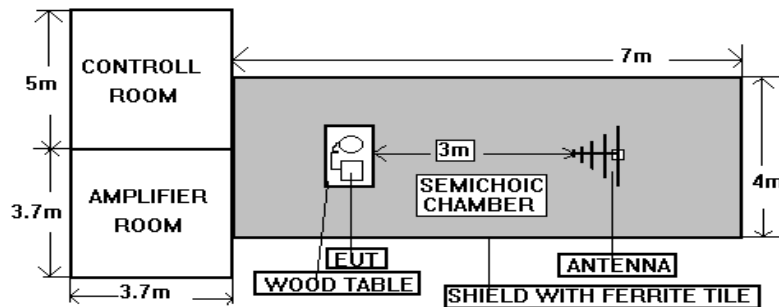

NOTE : The SPORTON 7m x 4m x 4m semicoic chamber is compliance with the sixteen points uniform field requirement as stated in IEC 1000-4-3 Section 6.2.

The procedure defined in this part requires the generation of electromagnetic fields within which the test sample is placed and its operation observed. To generate fields that are useful for simulation of actual (field) conditions may require significant antenna drive power and the resultant high field strength levels. To comply with local regulations and to prevent biological hazards to the testing personnel, it is recommended that these tests be carried out in a shielded enclosure or semicoic chamber.

10.2. Test Procedure

- a. The equipment to be tested is placed in the center of the enclosure on a wooden table. The equipment is then connected to power and signal leads according to pertinent installation instructions.
- b. The bilog antenna which is enabling the complete frequency range of 80-1000 MHz is placed 3m away from the equipment. The required field strength is determined by placing the field strength meter(s) on top of or directly alongside the equipment under test and monitoring the field strength meter via a remote field strength indicator outside the enclosure while adjusting the continuous-wave to the applicable antennae.
- c. The test is normally performed with the generating antenna facing each of four sides of the EUT. The polarization of the field generated by the broadband (bilog) antenna necessitates testing each position twice, once with the antenna positioned vertically and again with the antenna positioned horizontally.
- d. The dwell time at each frequency shall not be less than the time necessary for the EUT to be exercised, and able to respond. Sensitive frequencies e.g. clock frequency(ies) and harmonics or frequencies of dominant interest shall be analyzed separately.
- e. At each of the above conditions, the frequency range is swept 80-1000 MHz, pausing to adjust the R.F. signal level or to switch oscillators and antenna. The rate of sweep is in the order of 1.5×10^{-3} decades/s. The sensitive frequencies or frequencies of dominant interest may be discretely analyzed.

10.3. Test Severity Levels

Frequency Band : 80-1000 MHz

Level	Test field strength (V/m)
1	1
2	3
3	10
X	Specified

Remark : "X" is an open class.

Test Engineer: _____



Tony Hsu

10.4. Photographs of Radio Frequency Electromagnetic Field Immunity Test

FRONT VIEW



REAR VIEW



11. Electrical Fast Transient/Burst Immunity Test (EFT/BURST)

- FINAL TEST RESULT : **PASS**
- Pass Performance Criteria : A
- Required Performance Criteria : B
- Basic Standard : IEC 61000-4-4:2004
- Product Standard : EN 55024:1998/A1:2001/A2:2003
- Level : 2
- Test Voltage : $\pm 0.5 / \pm 1.0$ kV
- Temperature : 21
- Relative Humidity : 40 %
- Atmospheric Pressure : 103 kPa
- Test Date : Apr. 21, 2008
- Observation : Normal.

11.1. Test setup

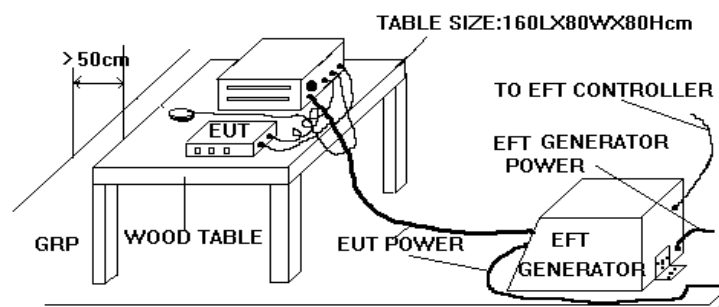

The EUT was placed on a ground reference plane and was insulated from it by an insulating support about 0.1m thick. If the EUT is table-top equipment, it was located approximately 0.8m above the GRP. The GRP was a metallic sheet (copper or aluminum) of 0.25 mm, minimum thickness; other metallic may be used but they shall have at least 0.65 mm thickness. It shall project beyond the EUT by at least 0.1m on all sides and connected to the protective earth. In the SPORTON EMC LAB. We provided 1 mm thickness aluminum ground reference plane or 1 mm thickness stainless steel ground reference plane. The minimum size of the ground reference plane is 1 m x 1 m, the exact size depending on the dimensions of the EUT. It was connected to the protective grounding system. The EUT was arranged and connected according to its functional requirements. The minimum distance between the EUT and other conductive structures, except the GRP. Beneath the EUT, was more than 0.5 m. Using the coupling clamp, the minimum distance between the coupling plates and all other conductive structures, except the GRP. Beneath the EUT, was more than 0.5 m. The length of the signal and power lines between the coupling device and the EUT was 1m or less.

11.2. Test on Power Line

- a. The EFT/B-generator was located on the GRP.. The length from the EFT/B-generator to the EUT as not exceed 1 m.
- b. The EFT/B-generator provides the ability to apply the test voltage in a non-symmetrical condition to the power supply input terminals of the EUT.

11.3. Test on Communication Lines

- a. The coupling clamp is composed of a clamp unit for housing the cable (length more than 3 m), and was placed on the GRP..
- b. The coupling clamp provides the ability of coupling the fast transient/bursts to the cable under test.

11.4. Test Procedure

- a. In order to minimize the effect of environmental parameters on test results, the climatic conditions when test is carrying out shall comply with the following requirements:
 - ambient temperature: 15°C to 35°C;
 - relative humidity : 45% to 75%;
 - atmospheric pressure : 86 kPa (860 mbar) to 106 kPa (1060 mbar).
- b. In order to minimize the effect of environmental parameters on test results, the electromagnetic environment of the laboratory shall not influence the test results.
- c. The variety and diversity of equipment and systems to be tested make it difficult to establish general criteria for the evaluation of the effects of fast transients/bursts on equipment and systems.
- d. The test results may be classified on the basic of the operating conditions and the functional specification of the equipment under test, according to the following performance criteria :
 - Normal performance within the specification limits.
 - Temporary degradation or loss of function or performance which is self-recoverable.
 - Temporary degradation or loss of function or performance which requires operator intervention or system reset.
 - Degradation or loss of function which is not recoverable due to damage of equipment (components).

11.5. Test Severity Levels

The following test severity levels are recommended for the fast transient/burst test :

Open circuit output test voltage $\pm 10\%$		
Level	On Power Supply	On I/O signal, data and control line
1	0.5 kV	0.25 kV
2	1.0 kV	0.50 kV
3	2.0 kV	1.00 kV
4	4.0 kV	2.00 kV
X	Specified	Specified

Remark : " X " is an open level. The level is subject to negotiation between the user and the manufacturer or is specified by the manufacturer.

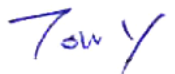
Test Engineer: 
Tony Hsu

11.6. Photographs of Electrical Fast Transient/BURST Immunity Test

FRONT VIEW



REAR VIEW



12. Surge Immunity Test

- FINAL TEST RESULT : **PASS**
- Pass Performance Criteria : A
- Required Performance Criteria : B
- Basic Standard : IEC 61000-4-5:1995/A1:2000
- Product Standard : EN 55024:1998/A1:2001/A2:2003
- Surge Wave Form (Tr/Th) : 1, 2/50 (8/20) μ s
- Level : 3
- Test Voltage : $\pm 0.5 / \pm 1.0 / \pm 2.0$ kV
- Temperature : 21
- Relative Humidity : 40 %
- Atmospheric Pressure : 103 kPa
- Test Date : Apr. 21, 2008
- Observation : Normal

12.1. Test Record

Voltage (kV)	Test Location	Polarity	Phase Angle				Test Result
			0°	90°	180°	270°	
1 kV	L - N	+	A	A	A	A	<u>PASS</u>
		-	A	A	A	A	<u>PASS</u>
2 kV	L - PE	+	A	A	A	A	<u>PASS</u>
		-	A	A	A	A	<u>PASS</u>
	N - PE	+	A	A	A	A	<u>PASS</u>
		-	A	A	A	A	<u>PASS</u>

⊕ Remark : PE = Earth reference

12.2. Test Level

Level	Open-circuit test voltage, $\pm 10\%$, kV
1	0.5
2	1.0
3	2.0
4	4.0
x	Specified

NOTE - x is an open class.
This level can be specified in the product specification.

12.3. Test Procedure

a. Climatic conditions

The climatic conditions shall comply with the following requirements :

- ambient temperature : 15 °C to 35 °C
- relative humidity : 10 % to 75 %
- atmospheric pressure : 86 kPa to 106 kPa (860 mbar to 1060 mbar)

b. Electromagnetic conditions

The electromagnetic environment of the laboratory shall not influence the test results.

c. The test shall be performed according the test plan that shall specify the test set-up with

- generator and other equipment utilized;
- test level (voltage/current);
- generator source impedance;
- internal or external generator trigger;
- number of tests : at least five positive and five negative at the selected points;
- repetition rate : maximum 1/min.
- inputs and outputs to be tested;
- representative operating conditions of the EUT;
- sequence of application of the surge to the circuit;
- phase angle in the case of a.c. power supply;
- actual installation conditions, for example :
 - AC : neutral earthed,
 - DC : (+) or (-) earthed to simulated the actual earthing conditions.

d. If not otherwise specified the surges have to be applied synchronized to the voltage phase at the zero-crossing and the peak value of the a.c. voltage wave (positive and negative).

e. The surges have to be applied line to line and line(s) and earth. When testing line to earth, the test voltage has to be applied successively between each of the lines and earth, if there is no other specification.



- f. The test procedure shall also consider the non-linear current-voltage characteristics of the equipment under test. Therefore the test voltage has to be increased by steps up to the test level specified in the product standard or test plan.
- g. All lower levels including the selected test level shall be satisfied. For testing the secondary protection, the output voltage of the generator shall be increased up to the worstcase voltage breakdown level (let-through level) of the primary protection.
- h. If the actual operating signal sources are not available, they may be simulated. Under no circumstances may the test level exceed the product specification. The test shall be carried out according to the test plan.
- i. To find all critical points of the duty cycle of the equipment, a sufficient number of positive and negative test pulses shall be applied. For acceptance test a previously unstressed equipment shall be used to the protection devices shall be replaced.

12.4. Operating Condition

Full system

Test Engineer: 
Tony Hsu

12.5. Photographs of Surge Immunity Test

FRONT VIEW



REAR VIEW



13. Conducted Disturbances Induced by Radio-Frequency Field Immunity Test (CS)

- FINAL TEST RESULT : **PASS**
- Pass Performance Criteria : A
- Required Performance Criteria : A
- Basic Standard : IEC 61000-4-6:1996/A1:2000
- Product Standard : EN 55024:1998/A1:2001/A2:2003
- Level : 2
- Test Voltage : 3 V rms (Modulated, 1KHz, 80%, AM)
- Frequency Range : 0.15 MHz to 80 MHz
- Frequency : 0.2, 1, 7.1, 13.56, 21, 27.12, 40.68MHz
- Dwell time : 2.9 seconds
- Frequency step size : 1 %
- Coupling mode : CDN-SW M3
- Temperature : 21
- Relative Humidity : 40 %
- Atmospheric Pressure : 103 kPa
- Test Date : Apr. 21, 2008
- Observation : Normal

13.1. Test Level

Level	Voltage Level (EMF)
1	1 V
2	3 V
3	10 V
x	Specified
NOTE - x is an open class. This level can be specified in the product specification.	

13.2. Operating Condition

Full system

13.3. Test Procedure

- a. The EUT shall be operated within its intended climatic conditions. The temperature and relative humidity should be recorded.
- b. This test method test can be performed without using a sell shielded enclosure. This is because the disturbance levels applied and the geometry of the setups are not likely to radiated a high amount of energy, especially at the lower frequencies. If under certain circumstances the radiated energy is too high, a shielded enclosure has to be used.
- c. The test shall be performed with the test generator connected to each of the coupling and decoupling devices in turn while the other non-excited RF-input ports of the coupling devices are terminated by a 50 ohm load resistor.
- d. The frequency range is swept from 150 kHz to 80 MHz, using the signal levels established during the setting process, and with the disturbance signal 80% amplitude modulated with a 1kHz sinewave, pausing to adjust the RF-signal level or to switch coupling devices as necessary. The rate of sweep shall no exceed 1.5×10^{-3} decades/s. Where the frequency is swept incrementally, the step size shall no exceed 1% of the start and thereafter 1% of the preceding frequency value.
- e. The dwell time at each frequency shall not be less than the time necessary for the EUT to be exercised, and able to respond. Sensitive frequencies e.g. clock frequency(ies) and harmonics or frequencies of dominant interest shall be analyzed separately.
- f. An alternative test procedure may be adopted, wherein the frequency range is swept incrementally, with a step size not exceeding 4% of the start ad thereafter 4% of the preceding frequency value. The test level should be at least twice the value of the specified test level.
- g. In cases of dispute, the test procedure using a step size not exceeding 1% of the start and thereafter 1% of preceding frequency value shall take precedence.
- h. Attempts should be made to fully exercise the EUT during testing, and to fully interrogate all exercise modes selected for susceptibility.
- i. The use of special exercising programs is recommended.
- j. Testing shall be performed according to a Test Plan, which shall be included in the test report.
- k. It may be necessary to carry out some investigatory testing in order to establish some aspects of the test plan.

Test Engineer: Tony Hsu
Tony Hsu

13.4. Photographs of CS tests

FRONT VIEW



REAR VIEW



14. Power Frequency Magnetic Field immunity tests

- FINAL TEST RESULT : **PASS**
- Pass Performance Criteria : A
- Required Performance Criteria : A
- Basic Standard : IEC 61000-4-8:1993/A1:2000
- Product Standard : EN 55024:1998/A1:2001/A2:2003
- Temperature : 21
- Relative Humidity : 40 %
- Atmospheric Pressure : 103 kPa
- Test Date : Apr. 21, 2008
- Observation : Normal

14.1. Test Record

Power Frequency Magnetic Field	Testing duration	Coil Orientation	Results
50Hz, 1A/m	1.0 Min	X-axis	Pass
50Hz, 1A/m	1.0 Min	Y-axis	Pass
50Hz, 1A/m	1.0 Min	Z-axis	Pass

14.2. Test Setup

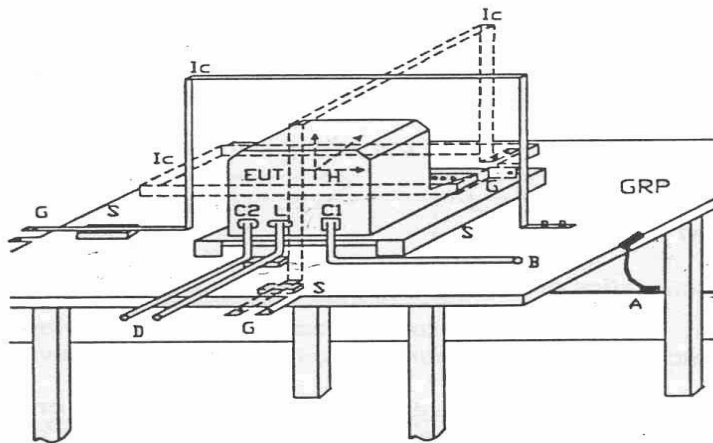

- | | |
|---------------------------|--------------------------------|
| GRP: Ground plane | C1: Power supply circuit |
| A: Safety earth | C2: Signal circuit |
| S: Insulating support | L: Communication line |
| EUT: Equipment under test | B: To power supply source |
| Lc: Induction coil | D: To signal source, simulator |
| E: Earth terminal | G: To the test generator |

Test Engineer: Tony Hsu
 Tony Hsu

14.3. Photographs of Power Frequency Magnetic Field Immunity Tests

FRONT VIEW



REAR VIEW



15. Voltage Dips and Voltage Interruptions Immunity Tests

- FINAL TEST RESULT : **PASS**
- Pass Performance Criteria : C for voltage interruption, A for voltage dips
- Required Performance Criteria : C for voltage interruption, B/C for voltage dips
- Basic Standard : IEC 61000-4-11:1994/A1:2000
- Product Standard : EN 55024:1998/A1:2001/A2:2003
- Temperature : 21
- Relative Humidity : 40 %
- Atmospheric Pressure : 103 kPa
- Test Date : Apr. 21, 2008
- Observation : Normal

15.1. Test Record of Voltage Interruption

Voltage (V)	Phase Angle		% Reduction	Duration (Periods)	Observation
	0 °	180 °			
100 / 240	C	C	>95%	250	After the interruption, the power of EUT reset automatically.

15.2. Test Record of Voltage Dips

Voltage (V)	Phase Angle		% Reduction	Duration (Periods)	Observation
	0 °	180 °			
100 / 240	A	A	30	25	Normal
100 / 240	A	A	>95 %	0.5	Normal

15.3. Testing Requirement and Procedure

The test was based on IEC 61000-4-11:1994/A1:2000

15.4. Test Conditions

1. Source voltage and frequency : 100V / 240V, 50Hz, Single phase.
2. Test of interval : 10 sec.
3. Level and duration : Sequency of 3 dips/interrupts.
4. Voltage rise (and fall) time : 1 ~ 5 μ s.

15.5. Operating Condition

Full system

Test Engineer: _____



Tony Hsu

15.6. Photographs of Voltage Dips and Voltage Interruptions Immunity Tests

FRONT VIEW



REAR VIEW



16. List of Measuring Equipment Used

<EMI>

Instrument	Manufacturer	Model No.	Serial No.	Characteristics	Calibration Date	Remark
Receiver	R&S	ESCS 30	100357	9 kHz - 2.75 GHz	Oct. 23, 2007	Conduction (CO01-NH)
LISN	AFJ	NNB-2/16Z	99081	9kHz – 30MHz	Dec. 21, 2007	Conduction (CO01-NH)
LISN	KYORITSU	KNW-407	8-1010-15	9kHz – 30MHz	Dec. 20, 2007	Conduction (CO01-NH)
Power Filter	CORCOM	MR12030	N/A	30A*2	N/A	Conduction (CO01-NH)
RF Cable-CON	Suhner Switzerland	RG223/U	CB004	9kHz – 30MHz	Dec. 16, 2007	Conduction (CO01-NH)
Open Area Test Site	SPORTON	OATS-10	OS02-NH	30 MHz - 1 GHz 10m, 3m	Jan. 05, 2008	Radiation (OS02-NH)
Amplifier	HP	8447D	2944A07523	0.1 MHz - 1.3 GHz	Apr. 24, 2007	Radiation (OS02-NH)
Receiver	R&S	ESCI	100497	9 kHz – 3 GHz	Jan. 09, 2008	Radiation (OS02-NH)
Bilog Antenna	CHASE	CBL6122B	2884	30 MHz - 2 GHz	Dec. 20, 2007	Radiation (OS02-NH)
Turn Table	EMCO	2080	9508-1805	0 - 360 degree	N/A	Radiation (OS02-NH)
Antenna Mast	ETS	2075-2	2385	1 m - 4 m	N/A	Radiation (OS02-NH)
RF Cable-R10m	MIYAZAKI	5DFB	CB002	30 MHz - 1 GHz	Sep. 19, 2007	Radiation (OS02-NH)

Calibration Interval of instruments listed above is one year.

<EMS>

Instrument	Manufacturer	Model No.	Serial No.	Characteristics	Calibration Date	Remark
ESD Generator	TESEQ AG	NSG 437	102	Air: 0 ~ 30 KV Contact: 0 ~15KV	Jul. 27, 2007	ESD
Amplifier	AMPLIFIER& RESEARCH	150W1000	312366	80M~1GHz	Sep. 10, 2007	RS
Amplifier	AMPLIFIER& RESEARCH	30S1G3	312505	80M~3GHz	Sep. 10, 2007	RS
DUAL DIRECTIONAL COUPLER	AMPLIFIER& RESEARCH	DC6180A	312453	0.8-4.2GHz	Sep. 10, 2007	RS
DUAL DIRECTIONAL COUPLER	AMPLIFIER& RESEARCH	DC7144A	312782	80-1GHz	Sep. 10, 2007	RS
Antenna	AMPLIFIER& RESEARCH	AT1080A	312637	80M~1GHz	Sep. 14, 2007	RS
Antenna	AMPLIFIER& RESEARCH	AT4002A	312601	80M~5GHz	Sep. 14, 2007	RS
INTEGRATED MEASUREMENT SYSTEM	ROHDE& SCHWARZ	IMS	100007	9kHz~3GHz	Sep. 12, 2007	RS
NRP-Z91 POWER SENSOR 6GHZ	ROHDE& SCHWARZ	1168.8004.02	100095	9kHz~3GHz	Sep. 12, 2007	RS
EFT Generator	KEYTEK	EMCPRO	0609221	0 KV - 4.4 KV	Sep. 05, 2007	EFT
SURGE Generator Bi-Wave	KEYTEK	EMCPRO	0609221	0 KV -6 KV/2 0KV-500V/12	Sep. 05, 2007	SURGE
SURGE/CDN	KEYTEK	EMCPRO	0609221	0 KV -4 KV/2 0KV-500V/12	Sep. 05, 2007	SURGE
SURGE Generator Ring-Wave	KEYTEK	EMCPRO	0609221	0 KV -6 KV/2 0KV-500V/12	Sep. 05, 2007	SURGE
CS	FRANKONIA	CIT-10	102C3115	100 kHz - 266 MHz	Sep. 05, 2007	CS
Attenuator	EM TEST	75W-DC-250 MHz 06	0004166A	150 kHz - 230 MHz	May 25, 2007	CS
Koppel- Eutkoppelnetzwerk	FRANKONIA	CDN M3	A3003012	150k~230MHz	May 13, 2007	CS
Magnetic Field Antenna	FCC	F-1000-4-8/9/10-L-1M	9830	0~125A	Apr. 07, 2008	Magnetic
Magnetic Generator	FCC	F-1000-4-8-G-125A	05004	0~125A	Apr. 07, 2008	Magnetic
PQF Generator	KEYTEK	EMCPRO	0609221	230VA/50Hz/60Hz 0%Open/5S 0%Short/5S 40%0.10S 70%/0.01S	Sep. 05, 2007	DIP
Harmonic/Flicker Test System	EMC PARTNER	Harmonics -1000	088	4000VA 16A PEAK	Sep. 05, 2007	Harmonics, Flicker

Calibration Interval of instruments listed above is one year.

17. Declaration of Conformity and the CE Mark

There are three possible procedures pertaining to the declaration of conformity :

17.1. Conformity Testing and Declaration of Conformity by the Manufacturer or His Authorized Representative Established within the Community or by an Importer.

- Article 10 (1) of the EMC Directive,
- § 3 (1) no. 2a of the EMC Act.

17.2. Declaration of Conformity Issued by the Manufacturer or His Authorized Representative Established within the Community or by an Importer Following Testing of the Product and Issued of an EC certificate of conformity by a competent body.

- Article 10 (2) of the EMC Directive,
- § 3 (1) no. 2b of the EMC Act.

17.3. Declaration of Conformity Issued by the Manufacturer or His Authorized Representative Established within the Community or by an Importer Following Testing and Certification of the Product by a Notified Body.

- Article 10 (5) of the EMC Directive,
- § 3 (1) no. 2b of the EMC Act (radio transmitting installations).

17.4. Specimen For The CE Marking Of Electrical / Electronical Equipment

The components of the CE marking shall have substantially the same vertical dimension, which may not be less than 5 mm.



APPENDIX A. Photographs of EUT







